



# Global Business of Credit Saison

15<sup>th</sup> December 2021

Credit Saison Co., Ltd.

# History of our Global Business

- ❑ After setting up the office in Singapore (Credit Saison Asia Pacific) in 2014, we accelerated our expansion into Southeast Asia and India.
- ❑ Also, we have been actively investing into some funds and payment companies.

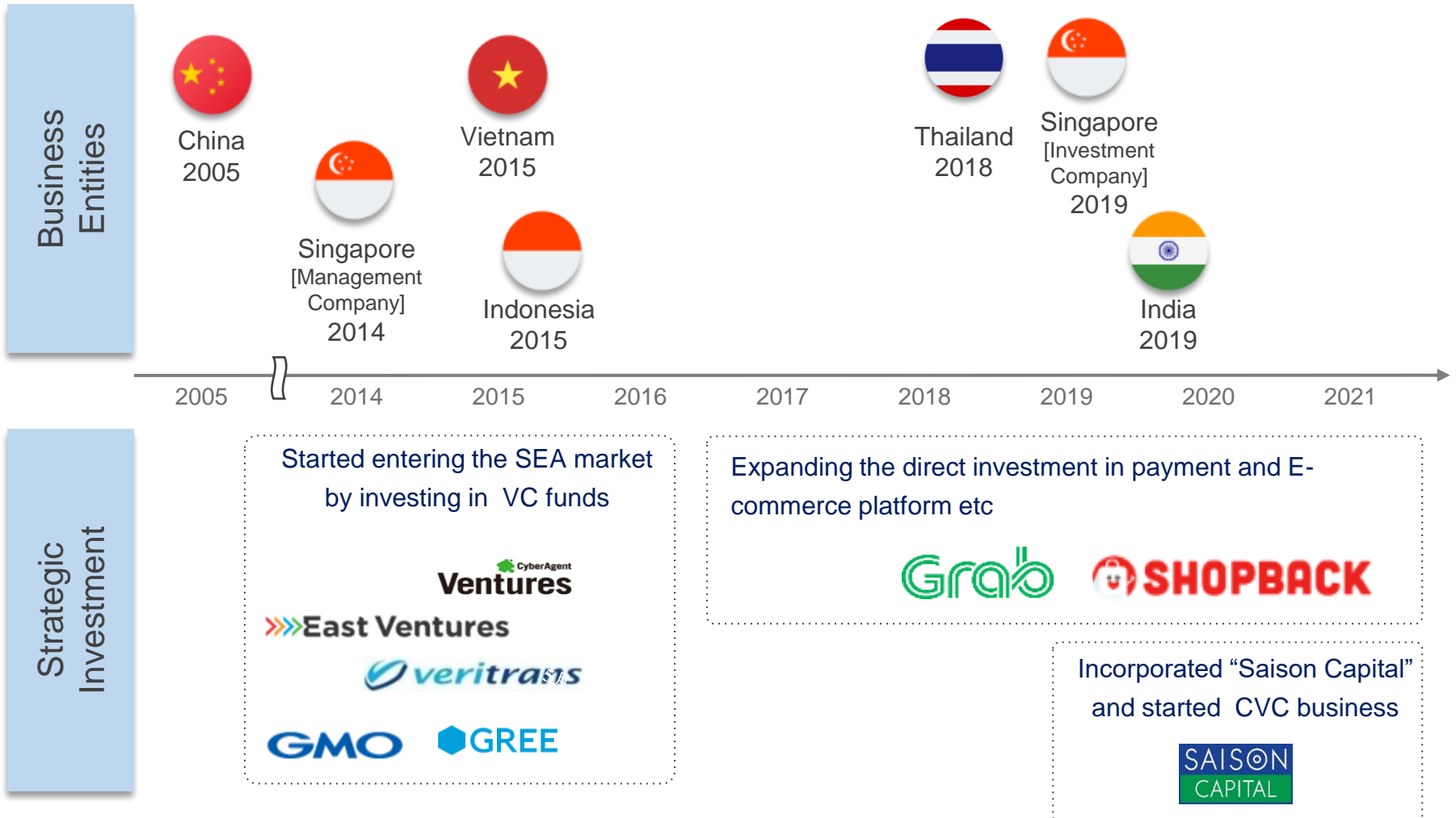

# Overseas' Group Companies

- As of 2021, we have expanded the business into 7 countries (including our domestic JV's subsidiary in Cambodia)



**Singapore**

---

**Credit Saison Asia Pacific Pte. Ltd.**

- Management of overseas businesses

---



**Saison Capital Pte. Ltd.**

- CVC business
- Impact Investment



**India**



**Kisetsu Saison Finance (India) Private Limited**

- Digital Lending



**Indonesia**



**PT. Saison Modern Finance**

- Digital Lending, Leasing



**Vietnam**



**HD SAISON Finance Company Ltd.**

- Retail Finance



**China**

**Credit Saison Corporation (Shanghai) Ltd.**

- Consulting



**Thailand**



**SIAM SAISON Co., Ltd.**

- Digital B2B Finance



**Cambodia**



**Idemitsu Saison Microfinance (Cambodia) Plc.**

- Lending, Installment Payment

## Vision of our Global Business

We offer **Digitalized and Localized Financial services** globally mainly in **Southeast Asia and India** to **“Underserved”** customers.

Through the global business activities, we promote **“Financial Inclusion”** and make it a core business of Credit Saison.

*※ Those who do not receive sufficient financial services from financial institutions such as banks, regardless of whether they have a bank account*

# Core Business Domains

Lending  
Business

Providing financial services targeting the “Underserved” individuals / SMEs



Investment  
Business

Earning investment returns + insights through global business development

# Key Clients of our “Lending Business”

- Implementing lending business targeting “Underserved” individuals and SMEs

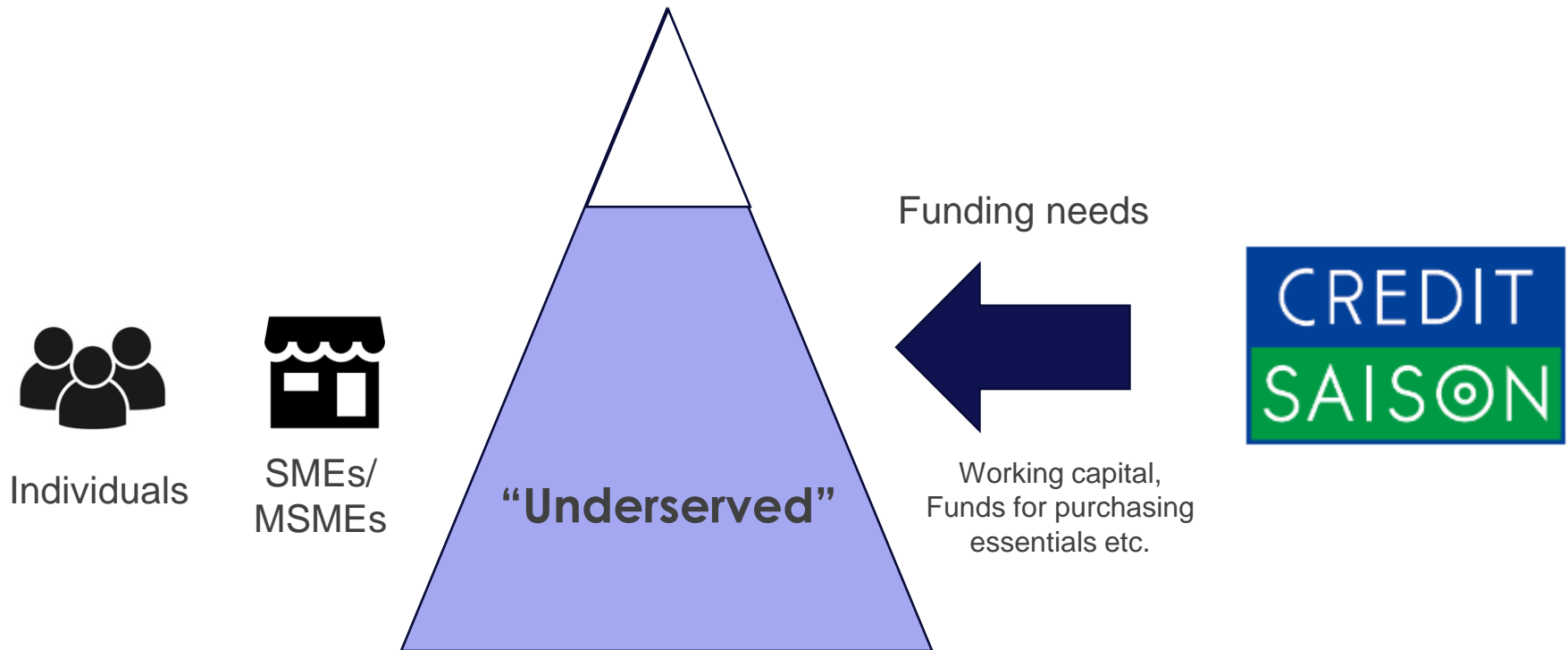

# Business Model of our “Lending Business”

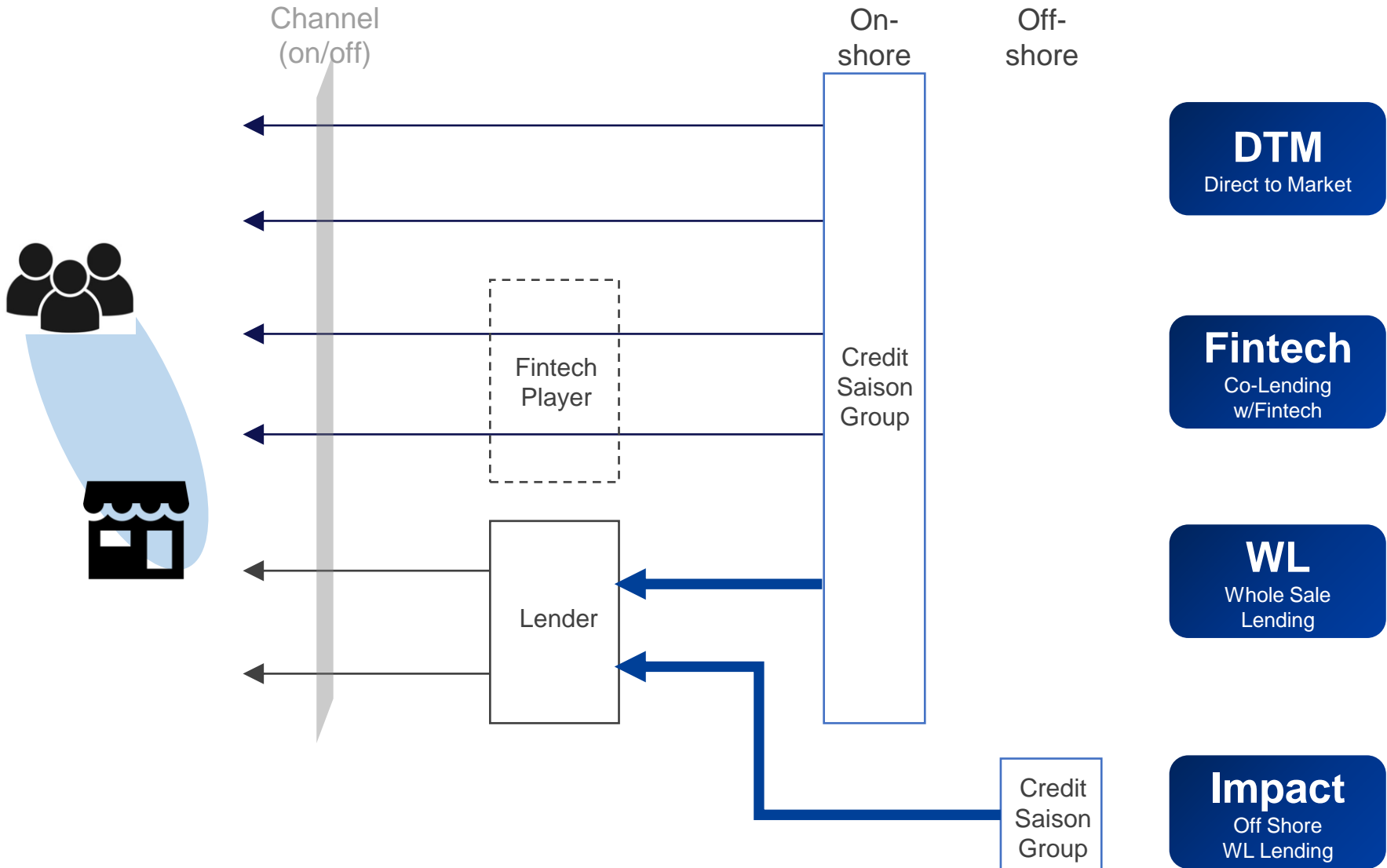

# Business Model of our "Lending Business"

## Models

**DTM**  
Direct to Market

**Fintech**  
Co-Lending w/Fintech

**WL**  
Whole Sale Lending

**Impact**  
Off Shore WL Lending

## Lending Schemes

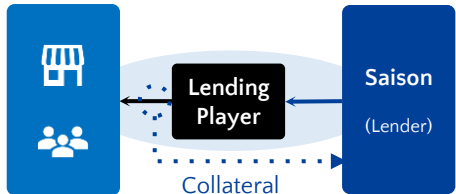
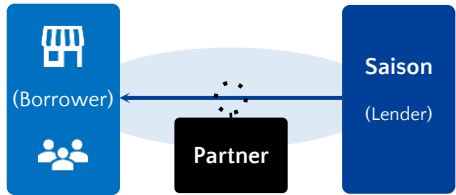
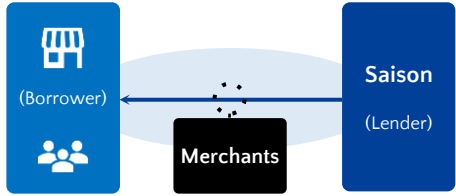

## Roles

■ Saison ■ Partner ■ Both



Providing installments and loans to customers with "plug-ins"



Providing "back finance" installments and loans via partners

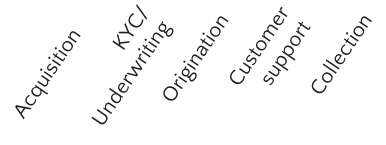

Providing funds to lending players

## Our Entities

▪ Vietnam **HD SAISON**  
FINANCE

▪ India **CREDIT SAISON**  
INDIA

▪ Indonesia **SAISON**  
INDONESIA

▪ India **CREDIT SAISON**  
INDIA

▪ Indonesia **SAISON**  
INDONESIA

▪ Singapore **SAISON**  
CAPITAL  
(Impact Investment Biz)



# Strategic Direction of our “Lending Business”

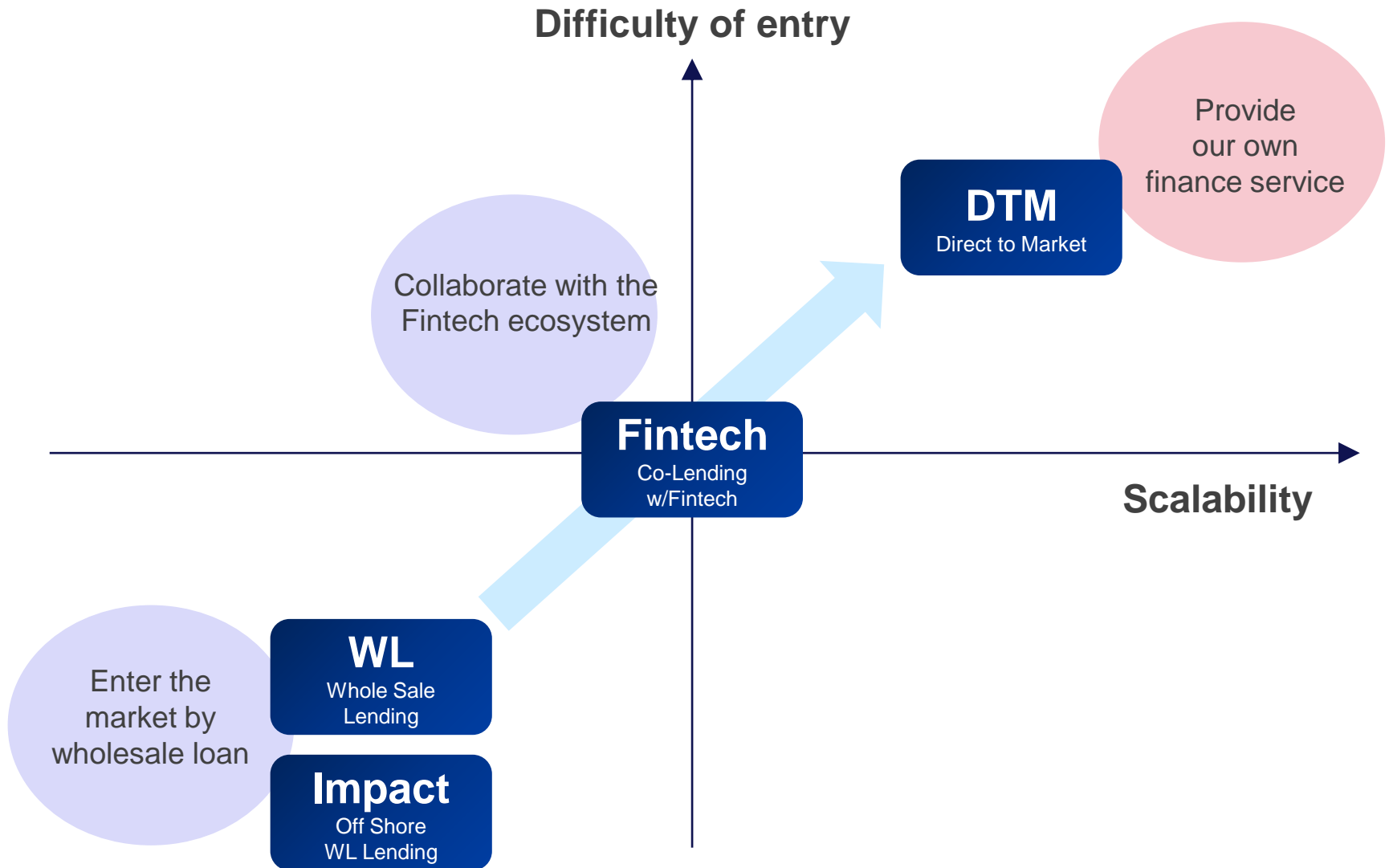

# Main Business ① HD Saison Finance - Vietnam

- ❑ Leading global business since 2015, via a JV with the local bank
- ❑ Expanding the installment / cash loan businesses throughout Vietnam targeting middle to low income layers



## HD SAISON Finance Company Ltd.

- Head office : Ho Chi Minh City
- Incorporation : 2007 (ex- Societe General Viet Finance)
- Shareholders : HDBank (50%)、Saison (49%)、Other(1%)
- Key Business : Motor bike loan, Electronic Device loan, Cash loan, Credit card etc.



**Loan Outstanding**

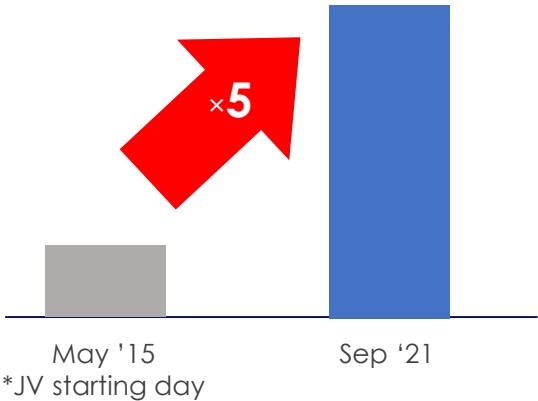

**Loan Portfolio**

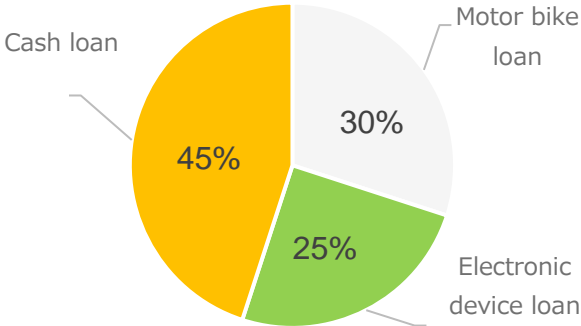

  
Domestic market share  
(Motor bike loans)  
**2nd \***

  
Point of Sales  
Over **20,000**

  
Consolidated  
Profit contribution  
**JPY1.3 billion \***

\*FiinReserch 「Vietnam Consumer Finance Report 2021」

\*FY March2021

# Main Business ②Kisetsu Saison Finance - India

- ❑ Achieved profitability in 2 years ( Net profit of about 200 million yen in 1H of this year)
- ❑ Digital lending business in collaboration with Fintech players under the local management teams



## Kisetsu Saison Finance (India) Private Limited

- Head office : Bangalore
- Incorporation : June, 2018
- Shareholders : Saison group (100%)
- Key Business : Whole Sale Lending, Co-Lending with fintech companies etc.



Number of Clients  
30 thousands



Long-term rating  
AA<sup>+</sup>



Operating  
50<sup>+</sup> Cities

\*By CRISIL (S&P Group)

Copyright © CREDITSAISON Co., Ltd. All Rights Reserved.

### Snapshot

※As of Nov'21

Outstanding Amount **JPY20 billion**

Disbursement Amount **JPY 5 billion / month**

Number of Employees **160**

### Partner



## Main Business ③ Impact Investments

- Completed Pilot-Phase and started full-scale deployment

### Impact Investment

### Scope

Financial  
Return

Measurable  
Social  
Benefit



**Sector**  
Financial  
Institution



**Area**  
SEA / India



**Asset Class**  
Private Debt  
/ Debt funding



**Financial Return**  
Market Level



**Social Impact**  
Financial  
Inclusion



貧困 男女平等 経済成長 産業・技術 不平等



### Borrower

Financial institutions  
contributing to Financial  
Inclusion, etc.



### Credit Saison

Expertise in  
finance Presence  
in Asia



### Capital Provider

Individual / institutional  
investors aiming for Impact  
Investment



## Objectives of our “Investment Business”

Through our Strategic Investments, we will achieve to;

- **Create new businesses and multi-tracks**
- **Enter unexplored markets**
- **Catch up on cutting-edge technologies and trends**
- **Achieve financial returns**

# Our Investment Story – “Grab” case study

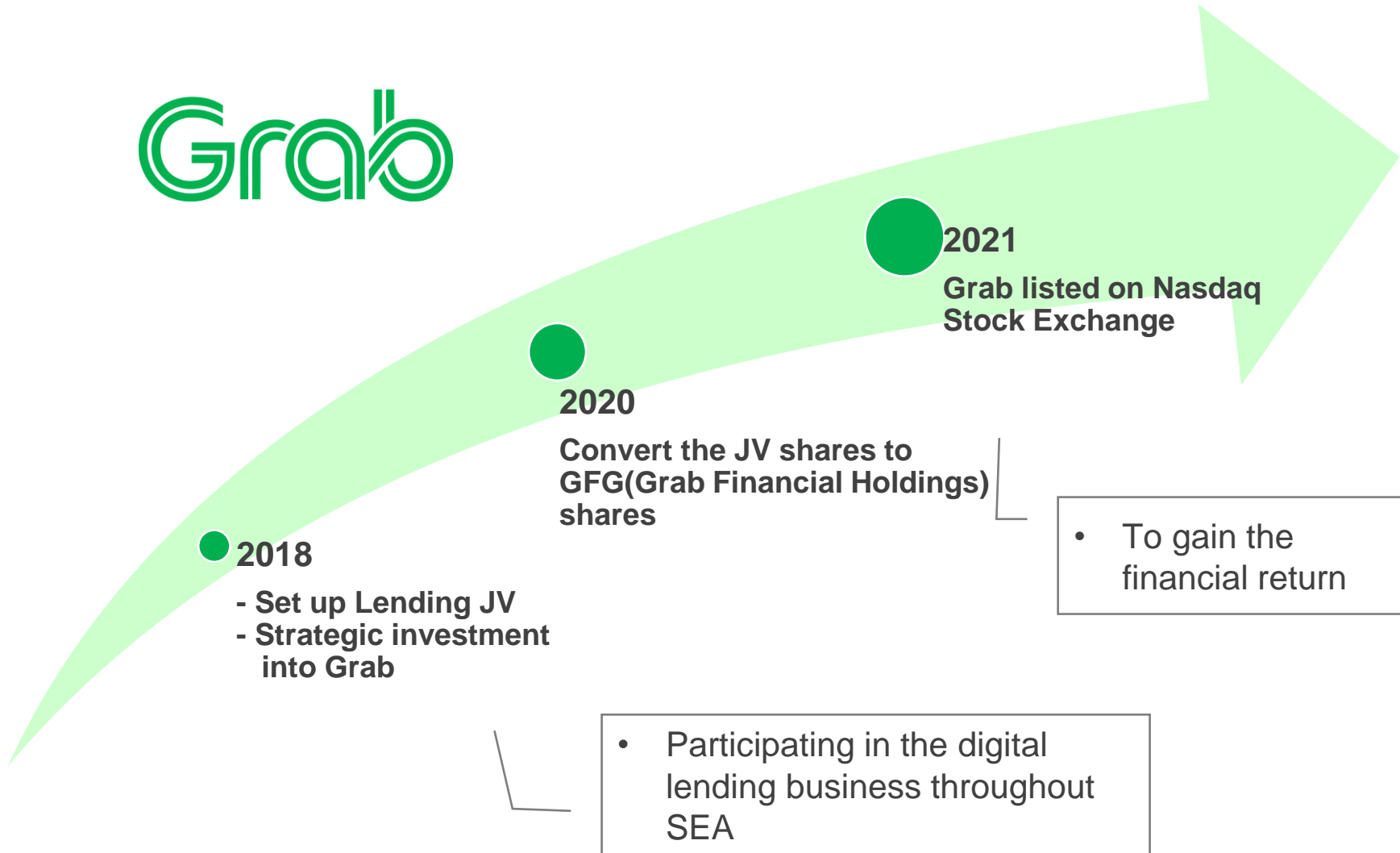

# CVC Business - Saison Capital



- ❑ Established in 2019. Expanding VC investments mainly in Southeast Asia and India
- ❑ Currently investing in over 40 companies and funds



## Saison Capital Pte. Ltd.

- Head office : Singapore
- Incorporation : 2019
- Shareholders : Credit Saison (100%)
- Key Business : CVC Business  
Impact Investment Business

### Target

- Fintech
- Embedded Finance
- Consumer / SaaS / Non-Fintech

### Investment Stage

- Early stage

### Key Investees





## Ula : B2B E-Commerce Platform (Indonesia)

- Jan 2020 Service launch
- Feb 2020 Saison Capital invested in Pre-Series A round
- Nov 2021 In Series B round, Jeff Bezos's fund invested to Ula  
→ 1<sup>st</sup> investment for Jeff Bezos's fund into SEA E-commerce start-up company



## Infina : Wealth management platform (Vietnam)

- Apr 2021 Saison Capital invested in Seed round
- Apr 2021~ Saison Capital Provides various business support such as product development, financing, networking etc to Infina
- May 2021 Well-known VCs participated in the Pre-series A round



**BukuKas**  
Bisnis Menjadi Mudah

## Bukukas : Financial management software for micro SMEs (Indonesia)

- Feb 2020 Saison Capital invested in Seed round
- Mar 2020~ Saison Capital provides business support in various aspects such as fund raising, recruitment, product development etc
- Jun 2020~ Succeeded in raising funds multiple times



## Our Strengths

**Professional and  
Talented local  
Management**

**Fast  
decision making  
and  
execution**

**Flexible and  
tailor-made  
Business Strategy**

# Professional and Talented Local Managements

## SAISON CAPITAL

- Investment Business



**Chris Sirise**  
Partner



**Rasaalika Singhania**  
Senior Vice President



## CREDIT SAISON ASIA PACIFIC

- Management for Global Business



**Keith Wong**  
Director,  
Corporate Finance & Strategy



**Annie Seah**  
Regional Finance Director



## KISETSU SAISON FINANCE

- Digital Lending Business



**Presha Paragash**  
CEO



**Anuj Gupta**  
CRO



# Fast Decision Making and Execution

## Key Case Study



Initially, we planned to set up our own consumer finance company in order to enter the market in Vietnam, but switched our strategy to investing in an existing company and started operations early (2015)



Established a lending business joint venture with Grab, a ride-hailing service provider operating throughout Southeast Asia (2018)



Established a 100% own non-bank company in India and acquired NBFC license (2019)



Established a company in Singapore, formed a team, and started CVC business and impact investment business.

# Flexible and Tailor-made Business Strategy

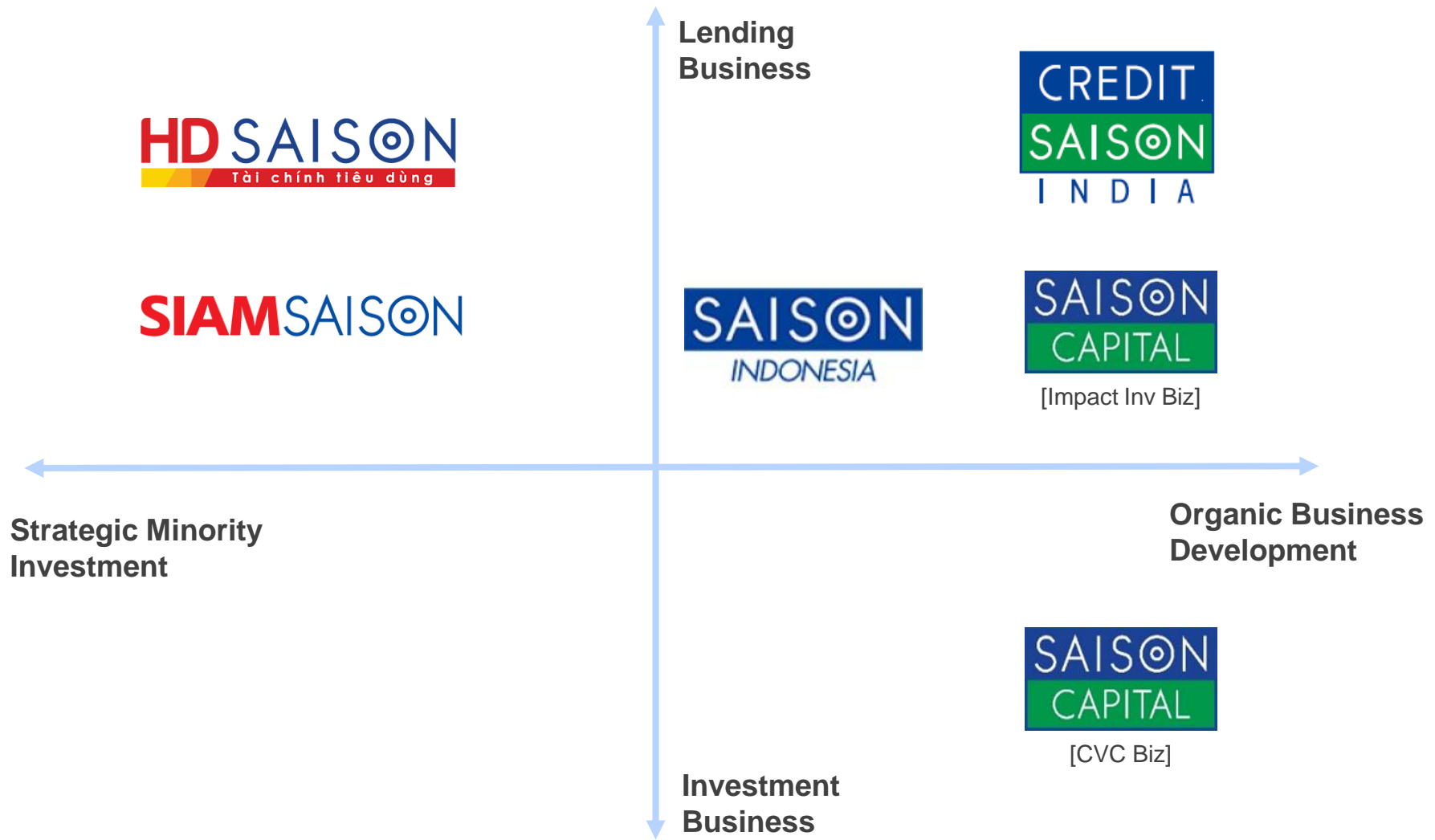



## Disclaimer

The statements in this material with respect to the plans and forecasts are forward-looking statements, except for the facts of the past, and involve uncertainties. Please note that actual business performance may significantly differ from these forecasts due to various factors.

Information in this material is not aimed at soliciting any investment. The company does not provide guarantees of any kind regarding the contents of this material. The company or parties providing the information assume no responsibility for any damages resulting from this material.